

PREPARED BY :    DATE	<h1>SHARP</h1> <p>TENRI LIQUID CRYSTAL DISPLAY DEVELOPMENT GROUP SHARP CORPORATION</p> <h2>SPECIFICATION</h2>	SPEC No. LD8Y11A
APPROVED BY :    DATE		FILE No.
		ISSUE : Nov. 22. 1996
		PAGE : 19 pages
		APPLICABLE GROUP Tenri Liquid Crystal Display Development Group

DEVICE SPECIFICATION FOR  

# TFT-LCD Module

  
 MODEL No.  

# LQ9D340

CUSTOMER'S APPROVAL

DATE \_\_\_\_\_

BY \_\_\_\_\_

PRESENTED

BY



H. FUKUOKA

Division Deputy General Manager

Engineering Department 2

TFT LCD Development Center

TENRI LIQUID CRYSTAL DISPLAY DEVELOPMENT GROUP

SHARP CORPORATION



## I. Application

This specification applies to color TFT-LCD module, LQ9D340.

These specification sheets are the proprietary product of SHARP CORPORATION ("SHARP") and include materials protected under copyright of SHARP. Do not reproduce or cause any third party to reproduce them in any form or by any means, electronic or mechanical, for any purpose in whole or in part, without the express written permission of SHARP.

The device listed in these specification sheets was designed and manufactured for use in general electronic equipment.

In case of using the device for applications such as control and safety equipment for transportation (aircraft, trains, automobiles, etc.), rescue and security equipment and various safety related equipment which require higher reliability and safety, take into consideration that appropriate measures such as fail-safe functions and redundant system design should be taken.

Do not use the device for equipment that requires an extreme level of reliability, such as aerospace applications, telecommunication equipment (trunk lines), nuclear power control equipment and medical or other equipment for life support.

SHARP assumes no responsibility for any damage resulting from the use of the device which does not comply with the instructions and the precautions specified in these specification sheets.

Contact and consult with a SHARP sales representative for any questions about this device.

## 2. Overview

This module is a color active matrix LCD module incorporating amorphous silicon TFTs (Thin Film Transistor). This module is composed of a color TFT-LCD panel, driver ICs, control circuit, power supply circuit and a backlight unit. Graphics and texts can be displayed on a  $640 \times 3 \times 480$  dots panel with 262,144 colors by supplying 18 bit data signals (6bit/color), four timing signals, +3.3V DC supply voltage for TFT-LCD panel driving and supply voltage for backlight.

Optimum viewing direction is 6 o'clock.

Backlight-driving DC/AC inverter is not built in this module.

## 3. Mechanical Specifications

Parameter	Specifications	Unit
Display size	21 (8.4") Diagonal	cm
Active area	170.9(H) $\times$ 129.6(V)	mm
Pixel format	640(H) $\times$ 480(V)	pixel
	(1 pixel = R + G + B dots)	
Pixel pitch	0.267(H) $\times$ 0.270(V)	mm
Pixel arrangement	R,G,B vertical stripe	
Display mode	Normally white	
Unit outline dimensions *1	216.0(W) $\times$ 152.4(H) $\times$ 7.3(D)	mm
Mass	260 $\pm$ 10	g
Surface treatment	Clear and hard-coating 2H	

\*1.Note: excluding backlight cables and mounting tabs.

Outline dimensions is shown in Fig.1

## 4. Input Terminals

## 4-1. TFT-LCD panel driving

		CN1	Used connector:DF9M-31P-1V (Hirose Electric Co., Ltd.)
1			31
			Corresponding connector: DF9-31S-1V ( " )
2			30
			DF9A-31S-1V
			DF9B-31S-1V

CN1 pin arrangement from module surface  
(Transparent view)

Pin No.	Symbol	Function	Remark
1	GND		
2	CK	Clock signal for sampling each data signal	
3	Hsync	Horizontal synchronous signal	【Note1】
4	Vsync	Vertical synchronous signal	【Note1】
5	GND		
6	R0	RED data signal (LSB)	
7	R1	RED data signal	
8	R2	RED data signal	
9	R3	RED data signal	
10	R4	RED data signal	
11	R5	RED data signal (MSB)	
12	GND		
13	G0	GREEN data signal (LSB)	
14	G1	GREEN data signal	
15	G2	GREEN data signal	
16	G3	GREEN data signal	
17	G4	GREEN data signal	
18	G5	GREEN data signal (MSB)	
19	GND		
20	B0	BLUE data signal (LSB)	
21	B1	BLUE data signal	
22	B2	BLUE data signal	
23	B3	BLUE data signal	
24	B4	BLUE data signal	
25	B5	BLUE data signal (MSB)	
26	GND		
27	ENAB	Signal to settle the horizontal display position	【Note2】
28	Vcc	+3.3V power supply	
29	Vcc	+3.3V power supply	
30	R/L	Horizontal display mode select signal	【Note3】
31	U/D	Vertical display mode select signal	【Note4】

※The shielding case is connected with GND.

【Note1】 One of 480-, 400- and 350-line mode is selected depending on the polarity combination of the both synchronous signals.

Mode	480 lines	400 lines	350 lines
Hsync	negative	negative	positive
Vsync	negative	positive	negative

【Note2】 The horizontal display start timing is settled in accordance with a rising edge of ENAB signal. In case ENAB is fixed "Low", the horizontal display start timing is determined as described in 7-2. Do not keep ENAB "High" during operation.

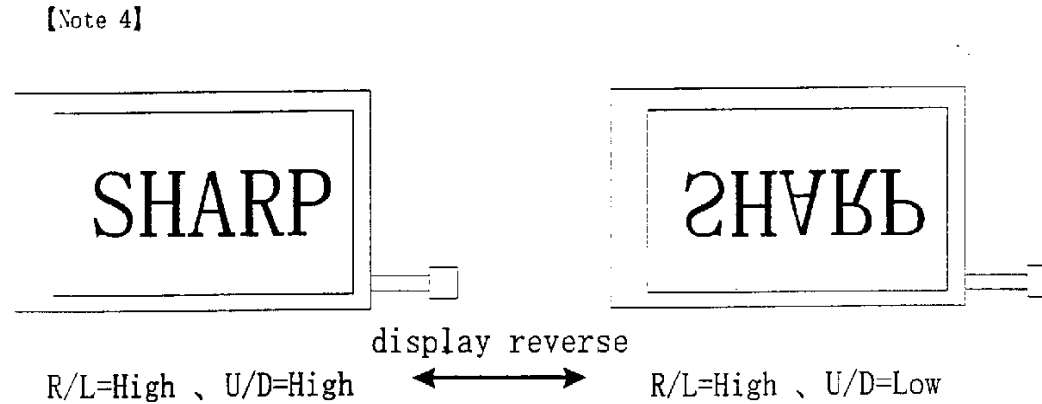
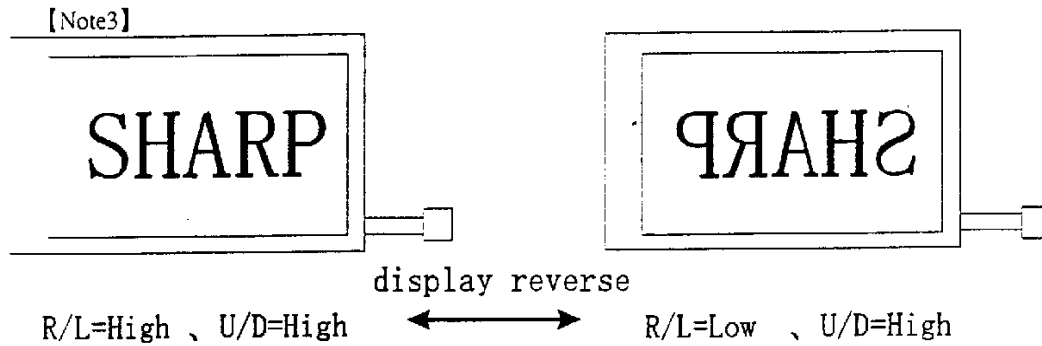

## 4.2. Backlight driving

Used connector : BHR-03VS-1(JST)

CN2

Corresponding connector :SM02(8.0)B-BHS(JST)

Pin no.	symbol	function
1	V <sub>HIGH</sub>	Power supply for lamp (High voltage side)
2	NC	This is electrically opened.
3	V <sub>LOW</sub>	Power supply for lamp (Low voltage side)

## 5. Absolute Maximum Ratings

Parameter	Symbol	Condition	Ratings	Unit	Remark
Input voltage	V <sub>I</sub>	Ta=25°C	-0.3 ~ V <sub>CC</sub> +0.3	V	【Note1】
V <sub>CC</sub> supply voltage	V <sub>CC</sub>	Ta=25°C	0 ~ +6	V	
Storage temperature	T <sub>stg</sub>	—	-25 ~ +60	°C	【Note2】
Operating temperature (Ambient)	T <sub>opa</sub>	—	0 ~ +50	°C	

【Note1】 CK,R0~R5,G0~G5,B0~B5,Hsync,Vsync,ENAB,R/L,U/D

【Note2】 Humidity : 95%RH Max. at Ta≤40°C.

Maximum wet-bulb temperature at 39°C or less at Ta&gt;40°C.

No condensation.

6. Electrical Characteristics

6-1. TFT-LCD panel driving

Ta=25°C

Parameter	Symbol	Min.	Typ.	Max.	Unit	Remark
Vcc	Supply voltage	Vcc	+3.3	+3.6	V	【Note1】
	Current dissipation	Icc	—	220	380	mA
Permissible input ripple voltage	V <sub>RP</sub>	—	—	100	mVp-p	Vcc=+3.3V
Input voltage (Low)	V <sub>IL</sub>	—	—	0.3Vcc	V	【Note3】
Input voltage (High)	V <sub>IH</sub>	0.7Vcc	—	—	V	
Input current (low)	I <sub>OL1</sub>	—	—	1.0	μA	V <sub>I</sub> =0V 【Note4】
	I <sub>OL2</sub>	300	—	—	μA	V <sub>I</sub> =0V 【Note5】
Input current (High)	I <sub>OH1</sub>	—	—	1.0	μA	V <sub>I</sub> =Vcc 【Note6】
	I <sub>OH2</sub>	2.0	—	30.0	μA	V <sub>I</sub> =Vcc 【Note7】

【Note1】

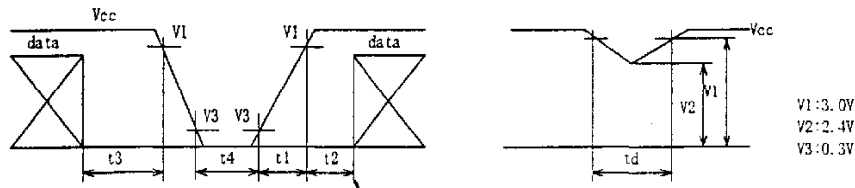

On-off condition for supply voltage.

- 0 < t1 ≤ 10ms
- 0 < t2 ≤ 10ms
- 0 < t3 ≤ 1s
- t4 ≥ 1s

Vcc-dip condition.

- 1) V2 ≤ Vcc < V1
- td ≤ 10ms
- 2) Vcc < V2

Vcc-dip conditions should also follow the Vcc-turn-on conditions.

【Note2】 Typical current situation : 64-gray-bar pattern.

480 line mode. Vcc=+3.3V

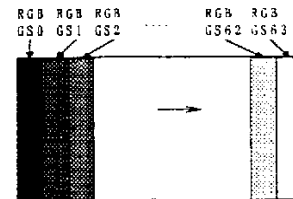

【Note3】 CK,R0~R5,G0~G5,B0~B5,Hsync,Vsync,ENAB,R/L,U/D

【Note4】 CK,R0~R5,G0~G5,B0~B5,Hsync,Vsync,ENAB

【Note5】 R/L,U/D

【Note6】 CK,R0~R5,G0~G5,B0~B5,Hsync,Vsync

【Note7】 ENAB

6-2. Backlight driving  $\triangle$ 

The backlight system is an edge-lighting type with single CCFT (Cold Cathode Fluorescent Tube). The characteristics of single lamp are shown in the following table.

Ta=25°C

Parameter	Symbol	Min.	Typ.	Max.	Unit	Remark
Lamp voltage	VL	—	397	—	Vrms	【Note2】
			370			【Note3】
Lamp current	IL	2.0	3.4	5.5	mArms	【Note1】 【Note2】
			5.5			【Note1】 【Note3】
Lamp power consumption	PL	—	1.35	—	W	【Note2】 【Note4】
			2.0			【Note3】 【Note3】
Lamp frequency	FL	20	35	60	KHz	【Note5】
Kick-off voltage	Vs	—	—	900	Vrms	Ta=25°C 【Note6】
				1000	Vrms	Ta=0°C 【Note6】
Lamp life time	LL	10000	—	—	hour	【Note7】

【Note1】 Lamp current is measured with current meter for high frequency as shown below.

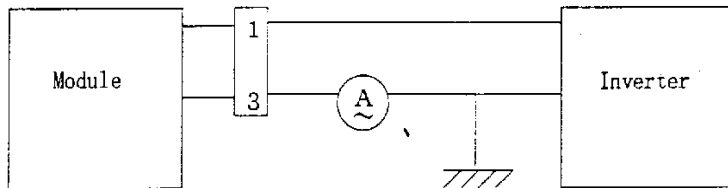

\* 3pin is V<sub>LOW</sub>

【Note2】 At the condition of  $Y_L=70\text{cd/m}^2$

【Note3】 At the condition of  $Y_L=115\text{cd/m}^2$

【Note4】 Calculated value for reference. ( $I_L \times V_L$ )

【Note5】 Lamp frequency may produce interference with horizontal synchronous frequency, and this may cause beat on the display. Therefore lamp frequency shall be detached as much as possible from the horizontal synchronous frequency and from the harmonics of horizontal synchronous to avoid interference.

【Note6】 The open output voltage of the inverter shall be maintained for more than 1 sec; otherwise the lamp may not be turned on.

【Note7】 Lamp life time ( $T_L$ ) is defined as the time when either ① or ② occurs in the continuous operation under the condition of  $T_a=25^\circ\text{C}$  and  $I_L=5.5\text{mArms}$

① Brightness becomes 50% of the original value under standard condition.

② Kick-off voltage at  $T_a=0^\circ\text{C}$  exceeds maximum value, 1000 Vrms.

Note) The performance of the backlight, for example life time or brightness, is much influenced by the characteristics of the DC-AC inverter for the lamp. When you design or order the inverter, please make sure that a poor lighting caused by the mismatch of the backlight and the inverter (miss-lighting, flicker, etc.) never occur. When you confirm it, the module should be operated in the same condition as it is installed in your instrument.



## 7. Timing Characteristics of input signals

Timing diagrams of input signal are shown in Fig.2 - 1~3.

## 7-1. Timing characteristics

Parameter		Symbol	Mode	Min.	Typ.	Max.	Unit	Remark
Clock	Frequency	1/Tc	all	—	25.18	28.33	MHz	
	High time	Tch	"	5	—	—	ns	
	Low time	Tcl	"	10	—	—	ns	
Data	Setup time	Tds	"	5	—	—	ns	
	Hold time	Tdh	"	10	—	—	ns	
Horizontal sync. signal	Cycle	TH	"	30.00	31.78	—	$\mu s$	
			"	770	800	900	clock	
	Pulse width	THp	"	2	96	200	clock	
Vertical sync. signal	Cycle	TV	480	515	525	560	line	
			400	445	449	480	line	
			350	447	449	510	line	
	Pulse width	TVp	all	2	—	34	line	
Horizontal display period		THd	"	640	640	640	clock	
Hsync-Clock phase difference		THc	"	10	—	Tc-10	ns	
Hsync-Vsync phase difference		TVh	"	0	—	TH-THp	clock	

Note) In case of lower frequency, the deterioration of display quality, flicker or noise etc., may be occurred.

## 7-2. Horizontal display position

The horizontal display position is determined by ENAB signal and the input data corresponding to the rising edge of ENAB signal is displayed at the left end of the active area.

Parameter		symbol	Min.	Typ.	Max.	Unit	Remark
Enable signal	Setup time	Tes	5	—	Tc-10	ns	
	Pulse width	Tep	2	640	640	clock	
Hsync-Enable signal phase difference		THE	44	—	164	clock	

Note) When ENAB is fixed "Low", the display starts from the data of C104(clock) as shown in Fig.2-1~3. Be careful that the module does not work when ENAB is fixed "High".

7-3. Vertical display position

The vertical display position is automatically centered in the active area at each mode of VGA ,480-,400-,and 350-line mode . Each mode is selected depending on the polarity of the synchronous signals described in 4-1(Note1).

In each mode ,the data of TVn is displayed at the top line of the active area. And the display position will be centered on the screen like the following figure when the period of vertical synchronous signal,TV,is typical value.

In 400-,and 350-line mode,the data in the vertical data invalid period is also displayed. So ,inputting all data "0" is recommended during vertical data invalid period.

ENAB signal has no relation to the vertical display position.

mode	V-data start(TVs)	V-data period(TVd)	V-display start(TVn)	V-display period	Unit	Remark
480	34	480	34	480	line	
400	34	400	443-TV	480	line	
350	61	350	445-TV	480	line	

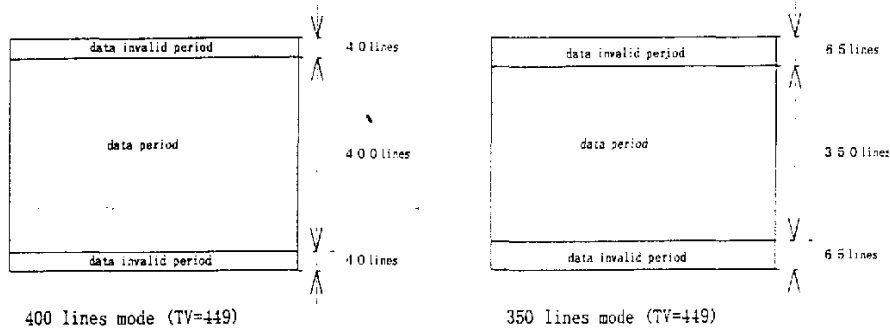

7-4. Input Data Signals and Display Position on the screen

Display position of input data (480 lines mode)  
(H, V)

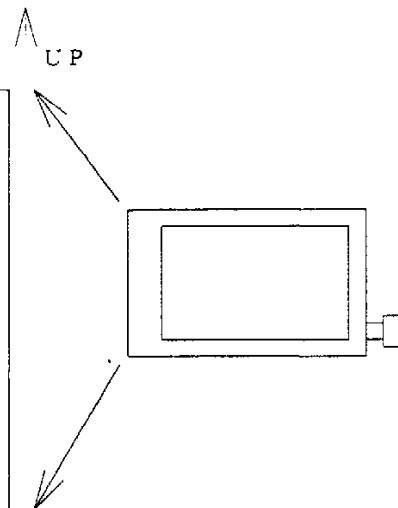
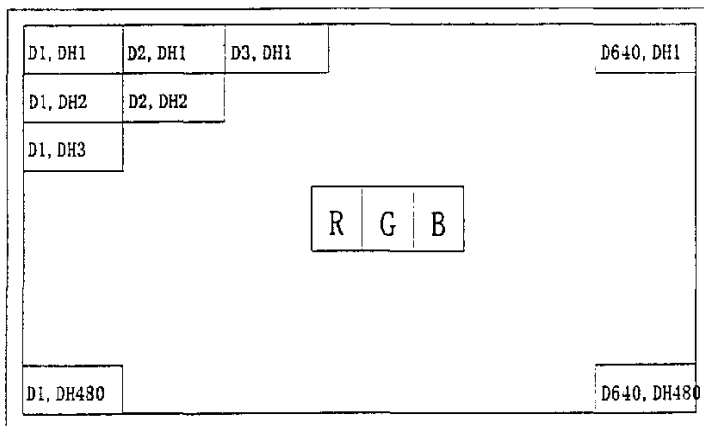

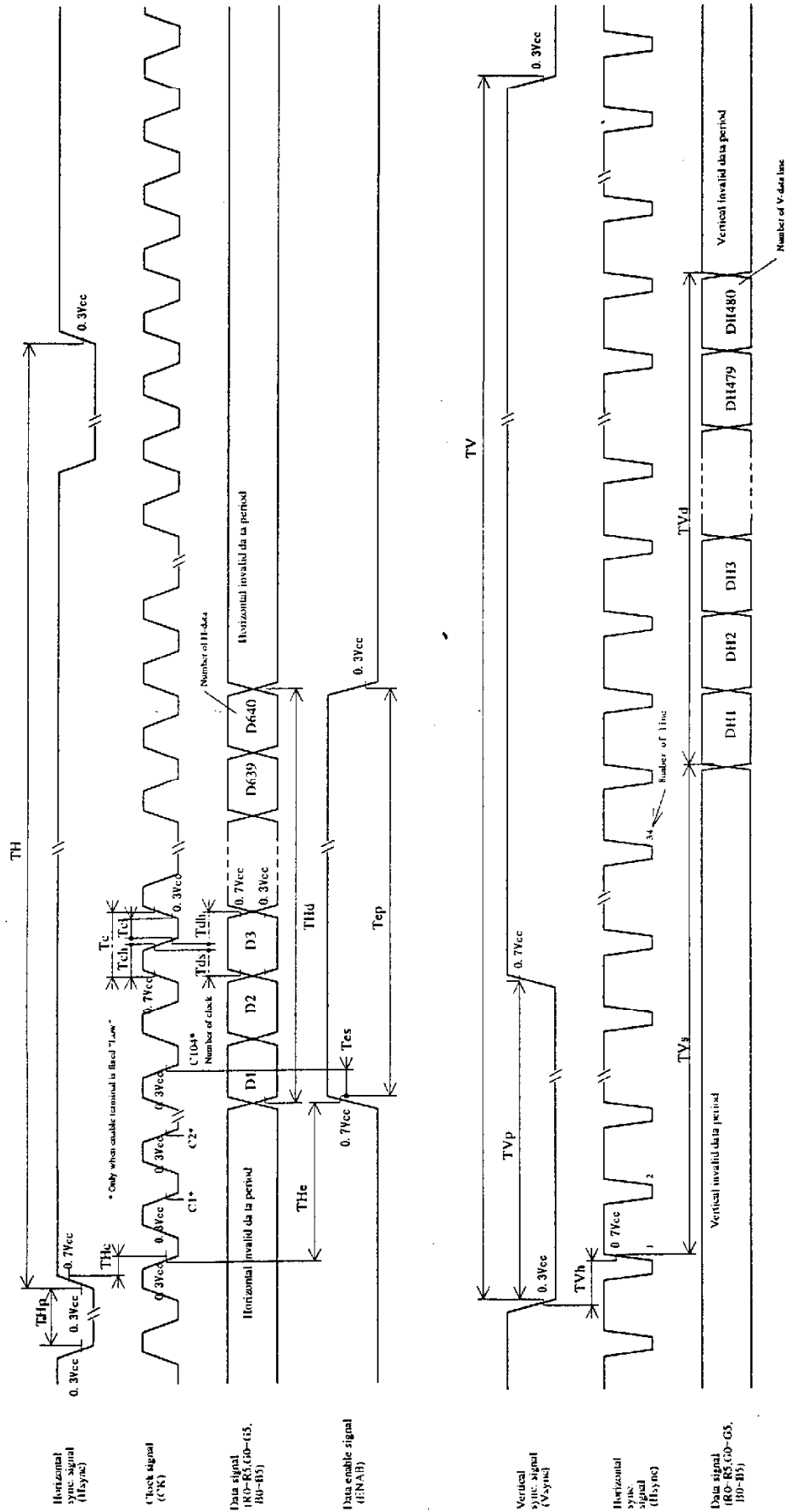

Fig 2-1 Input signal waveforms (480 line mode)



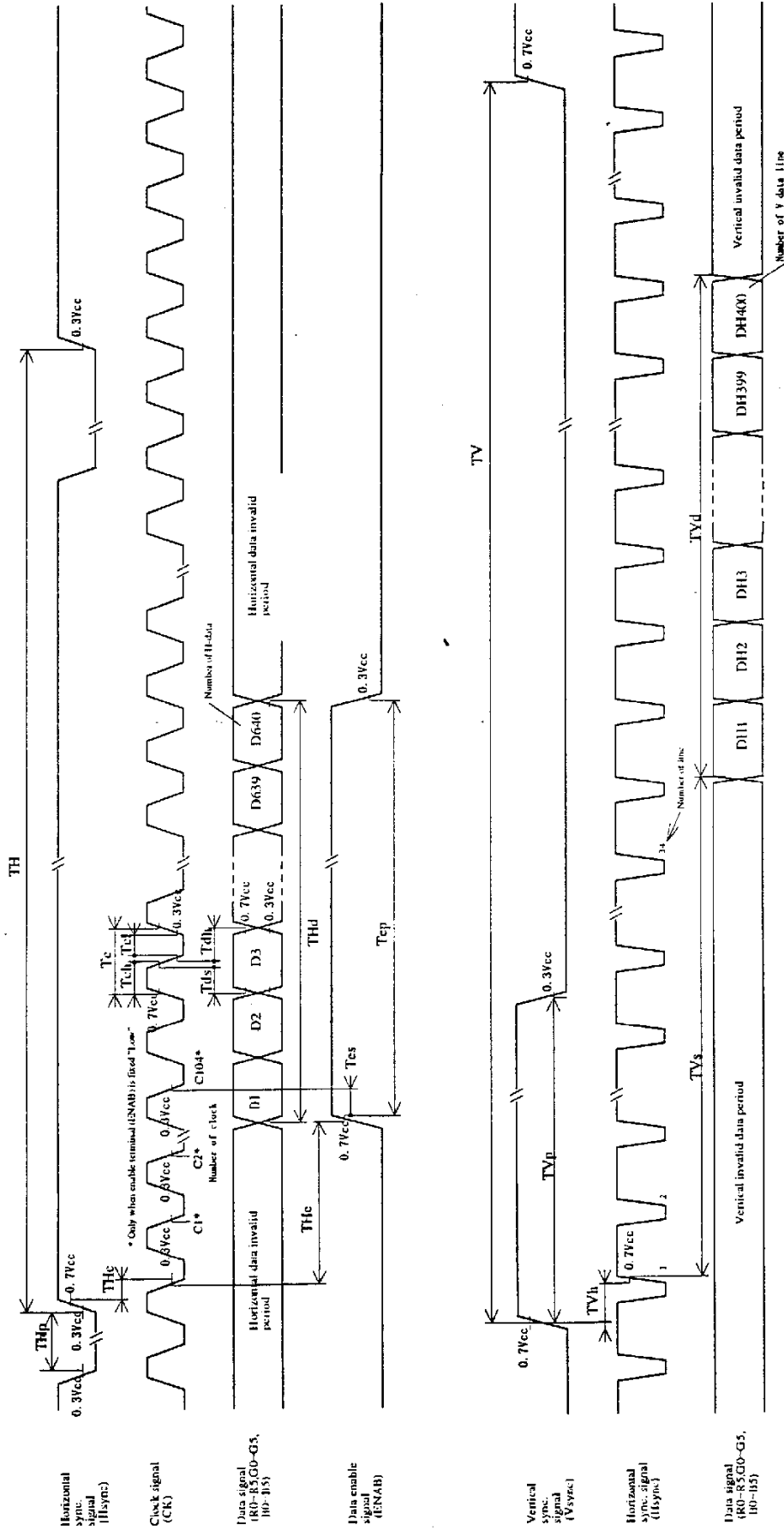

Fig.2-2 Input signal waveforms (400 line mode)

## 8. Input Signals, Basic Display Colors and Gray Scale of Each Color

	Colors & Gray scale	Data signal																		
		GrayScale	R0	R1	R2	R3	R4	R5	G0	G1	G2	G3	G4	G5	B0	B1	B2	B3	B4	B5
	Black	-	0	0	0	0	0	0	0	0	0	0	0	0	0	0	0	0	0	0
	Blue	-	0	0	0	0	0	0	0	0	0	0	0	0	1	1	1	1	1	1
	Green	-	0	0	0	0	0	0	1	1	1	1	1	1	0	0	0	0	0	0
	Cyan	-	0	0	0	0	0	0	1	1	1	1	1	1	1	1	1	1	1	1
	Red	-	1	1	1	1	1	1	0	0	0	0	0	0	0	0	0	0	0	0
	Magenta	-	1	1	1	1	1	1	0	0	0	0	0	0	1	1	1	1	1	1
	Yellow	-	1	1	1	1	1	1	1	1	1	1	1	1	0	0	0	0	0	0
	White	-	1	1	1	1	1	1	1	1	1	1	1	1	1	1	1	1	1	1
	Black	GS0	0	0	0	0	0	0	0	0	0	0	0	0	0	0	0	0	0	0
	↑	GS1	1	0	0	0	0	0	0	0	0	0	0	0	0	0	0	0	0	0
	Darker	GS2	0	1	0	0	0	0	0	0	0	0	0	0	0	0	0	0	0	0
	↑	↓																		
	↓	↓																		
	Brighter	GS61	1	0	1	1	1	1	0	0	0	0	0	0	0	0	0	0	0	0
	↓	GS62	0	1	1	1	1	1	0	0	0	0	0	0	0	0	0	0	0	0
	Red	GS63	1	1	1	1	1	1	0	0	0	0	0	0	0	0	0	0	0	0
	Black	GS0	0	0	0	0	0	0	0	0	0	0	0	0	0	0	0	0	0	0
	↑	GS1	0	0	0	0	0	0	1	0	0	0	0	0	0	0	0	0	0	0
	Darker	GS2	0	0	0	0	0	0	0	1	0	0	0	0	0	0	0	0	0	0
	↑	↓																		
	↓	↓																		
	Brighter	GS61	0	0	0	0	0	0	1	0	1	1	1	1	0	0	0	0	0	0
	↓	GS62	0	0	0	0	0	0	0	1	1	1	1	1	0	0	0	0	0	0
	Green	GS63	0	0	0	0	0	0	1	1	1	1	1	1	0	0	0	0	0	0
	Black	GS0	0	0	0	0	0	0	0	0	0	0	0	0	0	0	0	0	0	0
	↑	GS1	0	0	0	0	0	0	0	0	0	0	0	0	1	0	0	0	0	0
	Darker	GS2	0	0	0	0	0	0	0	0	0	0	0	0	0	1	0	0	0	0
	↑	↓																		
	↓	↓																		
	Brighter	GS61	0	0	0	0	0	0	0	0	0	0	0	0	1	0	1	1	1	1
	↓	GS62	0	0	0	0	0	0	0	0	0	0	0	0	0	1	1	1	1	1
	Blue	GS63	0	0	0	0	0	0	0	0	0	0	0	0	1	1	1	1	1	1

0 :Low level voltage, 1 : High level voltage

Each basic color can be displayed in 64 gray scales from 6 bit data signals. According to the combination of total 18 bit data signal the 262,144-color display can be achieved on the screen.

## 9. Optical Characteristics

Ta=25°C, Vcc=+3.3V

Parameter		Symbol	Condition	Min.	Typ.	Max.	Unit	Remark
Viewing angle range	Vertical	$\theta_{11}$	CR>10	30	—	—	Deg.	【Note1,4】
		$\theta_{12}$		50	—	—	Deg.	
	Horizontal	$\theta_{21}, \theta_{22}$		50	—	—	Deg.	
Contrast ratio		CR	$\theta = 0^\circ$	100	—	—		【Note2,4】
Response time	Rise	$\tau_r$		—	20	—	ms	【Note3,4】
	Decay	$\tau_d$		—	40	—	ms	
Chromaticity of white		x		—	0.313	—		【Note4】
		y		—	0.329	—		
Luminance of white $\triangle$		$Y_L$	—	70	—	cd/m <sup>2</sup>	$I_L=3.4\text{mA}$ 【Note4】	
			—	115	—		$I_L=5.5\text{mA}$ 【Note4】	
White Uniformity		$\delta_w$		—	—	1.45		【Note5】

※The measurement shall be executed 30 minutes after lighting at rating.

The optical characteristics shall be measured in a dark room or equivalent state with the method shown in Fig.3 below.

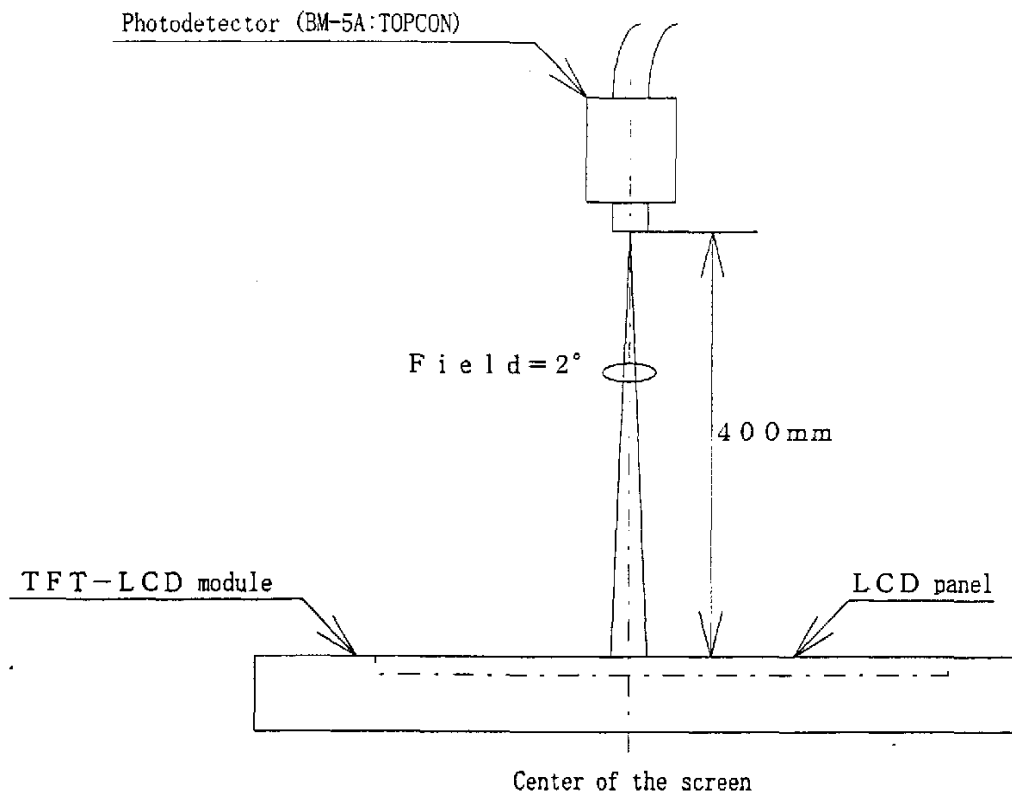
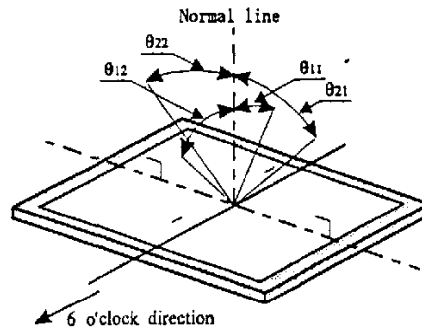

Fig.3 Optical characteristics measurement method

【Note1】 Definitions of viewing angle range:



【Note2】 Definition of contrast ratio:

The contrast ratio is defined as the following.

$$\text{Contrast Ratio (CR)} = \frac{\text{Luminance (brightness) with all pixels white}}{\text{Luminance (brightness) with all pixels black}}$$

【Note3】 Definition of response time:

The response time is defined as the following figure and shall be measured by switching the input signal for "black" and "white".

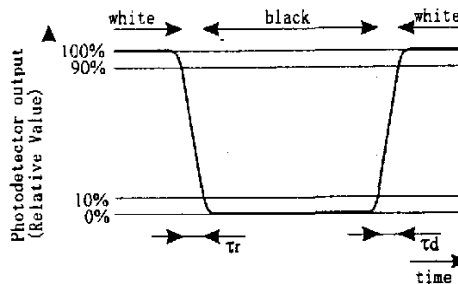

【Note4】 This shall be measured at center of the screen.

【Note5】 Definition of white uniformity:

White uniformity is defined as the following with five measurements (A~E).

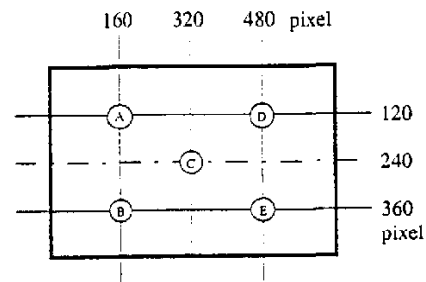

$$\delta_w = \frac{\text{Maximum Luminance of five points (brightness)}}{\text{Minimum Luminance of five points (brightness)}}$$

## 10. Display Quantity

The display quality of the color TFT-LCD module shall be in compliance with the Incoming Inspection Standard.



### 11. Handling Precautions

- a) Be sure to turn off the power supply when inserting or disconnecting the cable.
- b) Be sure to design the cabinet so that the module can be installed without any extra stress such as warp or twist.
- c) Since the front polarizer is easily damaged, pay attention not to scratch it.
- d) Wipe off water drop immediately. Long contact with water may cause discoloration or spots.
- e) When the panel surface is soiled, wipe it with absorbent cotton or other soft cloth.
- f) Since the panel is made of glass, it may break or crack if dropped or bumped on hard surface. Handle with care.
- g) Since CMOS LSI is used in this module, take care of static electricity and injure the human earth when handling.
- h) Observe all other precautionary requirements in handling components.
- i) Laminated film is attached to the module surface to prevent it from being scratched. Peel the film off slowly, just before the use, with strict attention to electrostatic charges. Ionized air shall be blown over during the action. Blow off 'dust' on the polarizer by using an ionized nitrogen gun, etc.

### 12. Packing form

- a) Piling number of cartons : MAX.7
- b) Package quantity in one carton : 10pcs
- c) Carton size : 374 (W)×254(D)×314(H)mm
- d) Total mass of 1 carton filled with full modules : 4100g

Packing form is shown in Fig.4

## 13. Reliability test items

No.	Test item	Conditions
1	High temperature storage test	Ta=60°C 240h
2	Low temperature storage test	Ta=-25°C 240h
3	High temperature & high humidity operation test	Ta=40°C ; 95%RH 240h (No condensation)
4	High temperature operation test	Ta=50°C 240h
5	Low temperature operation test	Ta=0°C 240h
6	Vibration test (non- operating)	Frequency : 10~57Hz/Vibration width (one side):0.075mm : 58~500Hz/Gravity:9.8m/s <sup>2</sup> Sweep time : 11 minutes Test period : 3 hours (1 hour for each direction of X,Y,Z)
7	Shock test (non- operating)	Max. gravity : 490m/s <sup>2</sup> Pulse width : 11ms, half sine wave Direction : ±X, ±Y, ±Z once for each direction.
8	Pressure durability test	Pressure : 196N To conduct the test based on following condition 【Note1】 , and to check if there is any failure except for load after the test.

## 【Result Evaluation Criteria】

Under the display quality test conditions with normal operation state, these shall be no change which may affect practical display function.

## 【Note1】 Load condition at rear side of the module.

Permanent cosmetic functional failure do not happen with the pressure applied at every 19.6N step through the metallic circular cylinder(30mm diameter) placed at the center back side (backlight side) of the working LCD module fixed at 4 mounting portions.

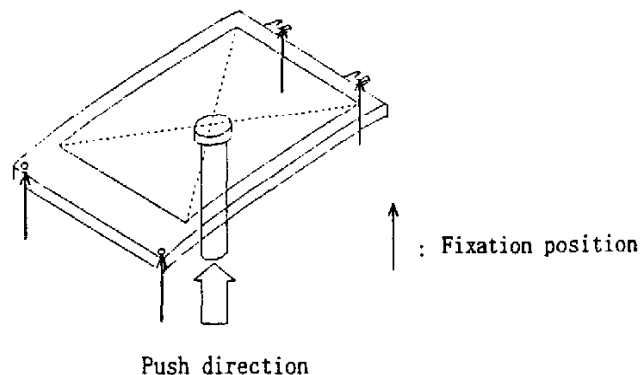

Since glass substrate is used in LCD panel, partial pressure and/or stress on the LCD may cause the damage like glass crack. Please design the product with enough margin to endure the pressure or stress, taking actual usage condition of the module in your product into consideration..

#### 14. Others

1) Lot No. Label:

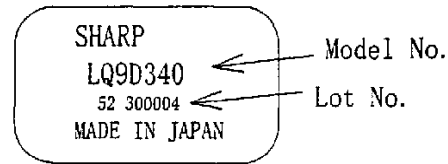

- 2) Adjusting volume have been set optimally before shipment, so do not change any adjusted value.  
If adjusted value is changed, the specification may not be satisfied.
- 3) Disassembling the module can cause permanent damage and should be strictly avoided.
- 4) Please be careful since image retention may occur when a fixed pattern is displayed for a long time
- 5) If any problem occurs in relation to the description of this specification , it shall be resolved through discussion with spirit of cooperation.

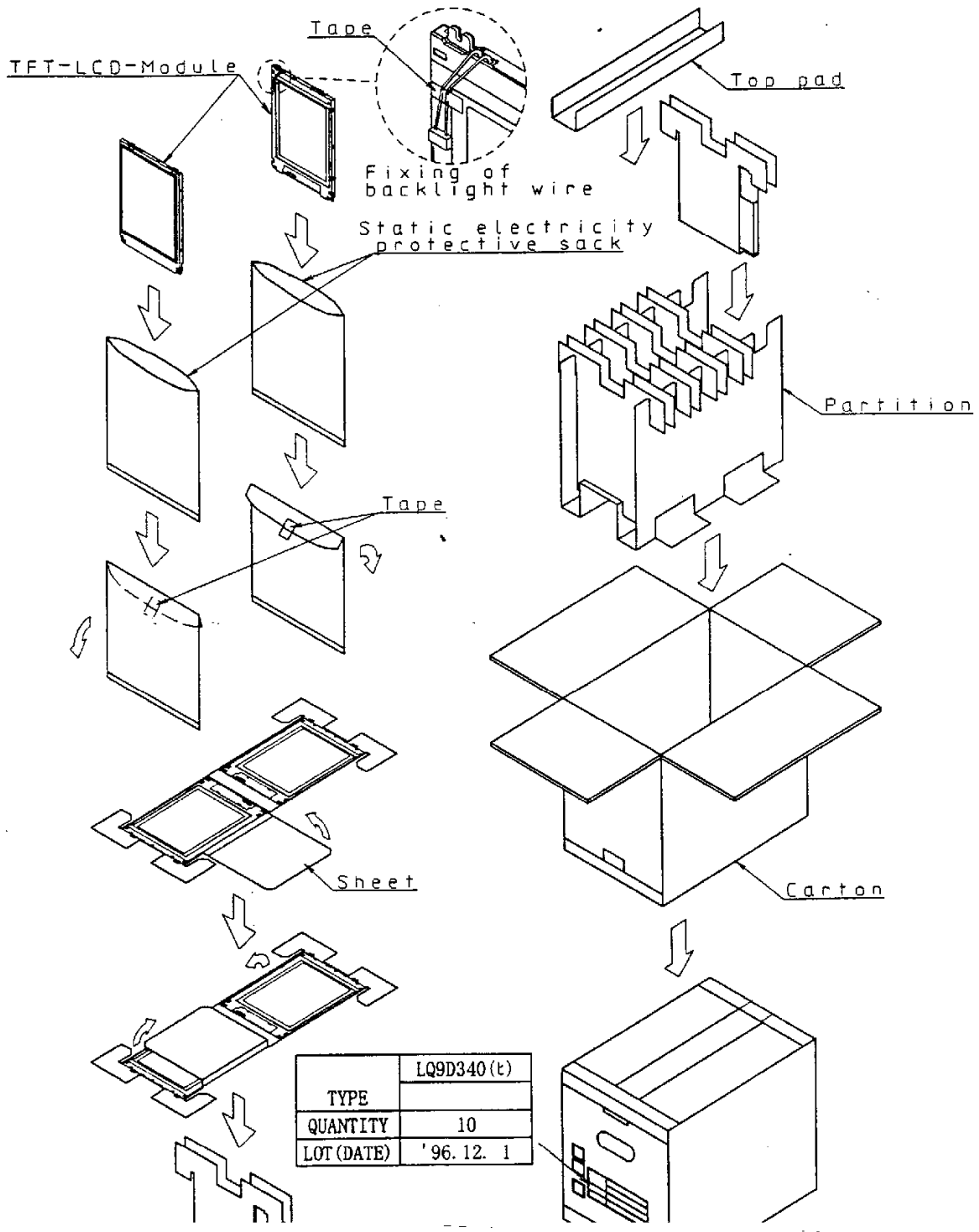

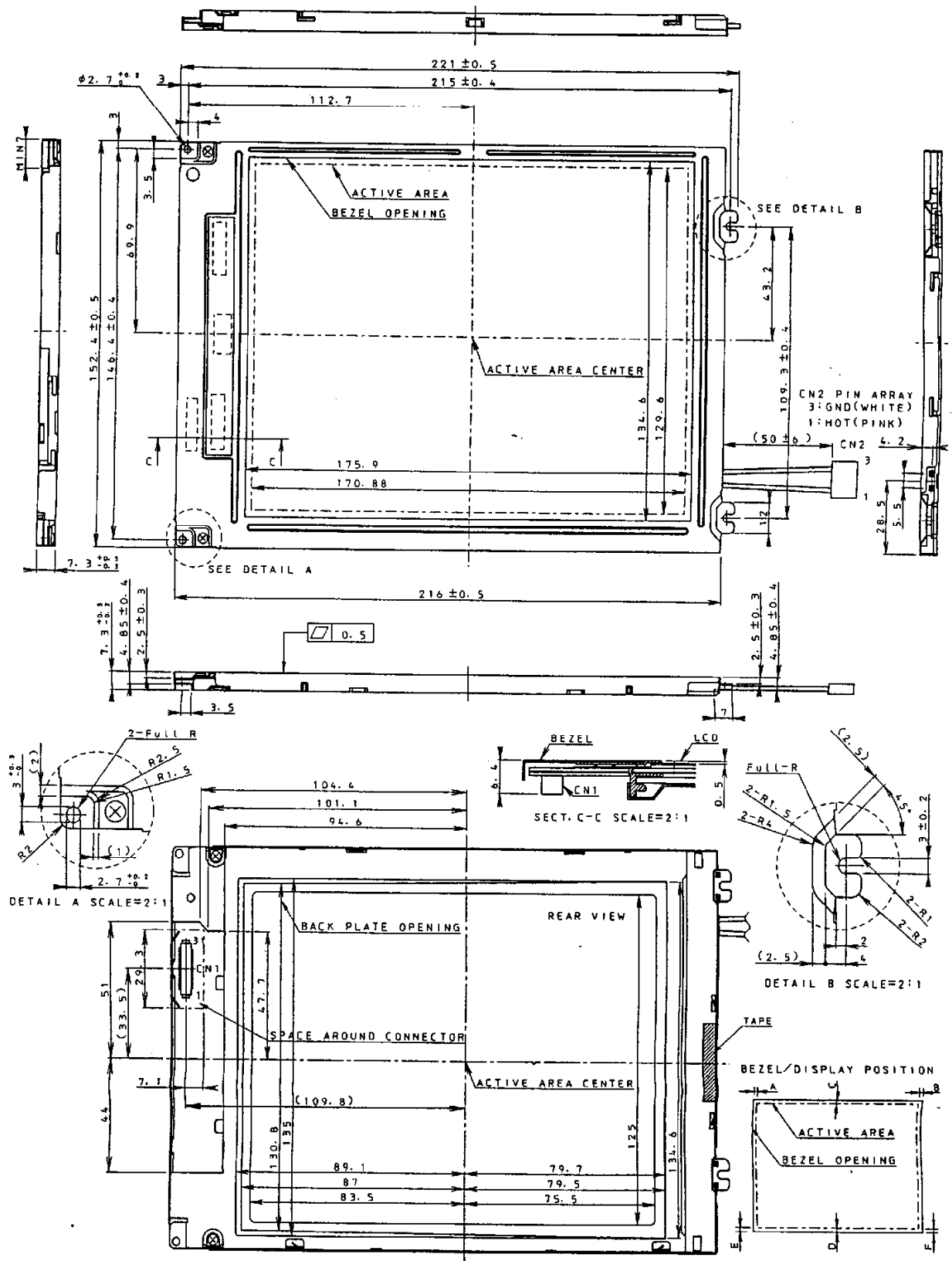

NOTES

Unspecified tolerance shall be  $\pm 0.5$   
 CN1: DF9-31P-1V (HIROSE)  
 CN2: BMR-03VS-1 (JST)

- 1) TOLERANCE X-DIRECTION A:  $2.51 \pm 0.8$
- 2) TOLERANCE X-DIRECTION B:  $2.51 \pm 0.8$
- 3) TOLERANCE Y-DIRECTION C:  $2.5 \pm 0.8$
- 4) TOLERANCE Y-DIRECTION D:  $2.5 \pm 0.8$
- 5) OBLIQUITY OF DISPLAY AREA  $\leq 0.8$

Fig. 1. Outline dimensions